

Product Data Sheet

DS2x2000 2 channel x 2000 Watt Triac Dimmer

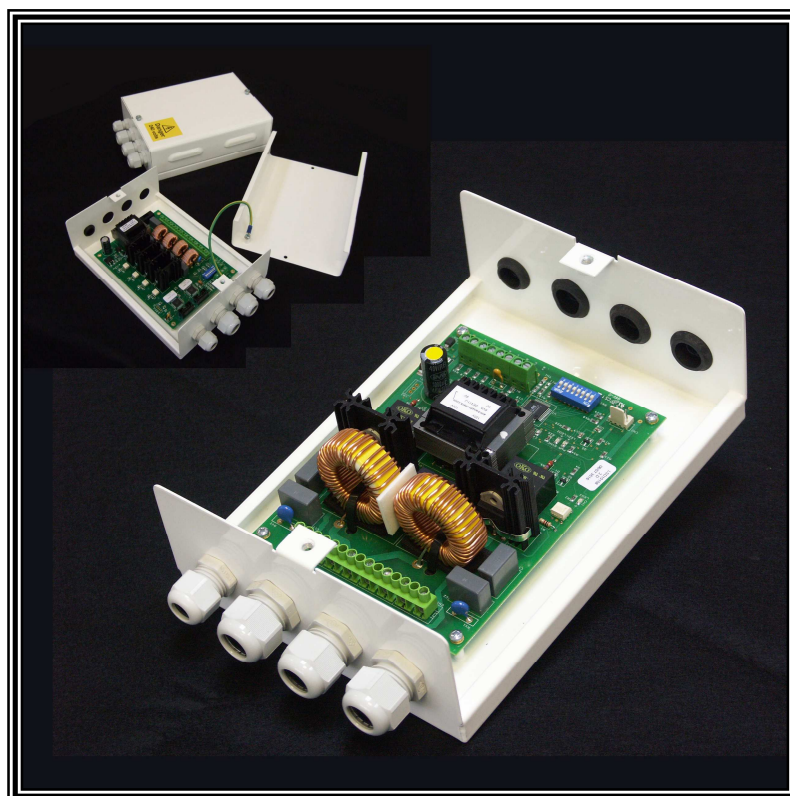

Introduction

The DS2x2000 is a 2 channel, triac-controlled, leading edge dimmer, designed to drive incandescent lamp loads up to 2000 watts per channel. When used in conjunction with control plates from the LUCID range, a scene based lighting control system with infra-red capability can be constructed to suit installations both large and small. The control plates are connected to the dimmer using low voltage CAT5 style cable and data communication is supported by the Hy-Net protocol, which is a proven robust interface with an integral watchdog facility.

Technical Specifications

Supply	230Vac 50/60Hz
Outputs	2 x 8A
Output fuses	20x5mm 10AT
Surge	400A, 20mS
Phase Control	Leading Edge Triac
Turn On	Soft Start Lamp Current
EMC	Iron Powder Core Chokes
Cable Entries	3 x 20mm 1 x 16mm Glands
Control Input	Hy-Net Serial Data
Internal Controls	Zone-Channel DIP Switch
Indicators	Power & Diagnostic LEDs
Operating Temp	0 – 40°C Ambient
Enclosure	Powder Coated Steel
Colour	Gloss White

Suitable Loads

Tungsten GLS, Leading Edge Electronic Transformers, Iron Transformers.

Similar Products

A single channel variant is also available. DS1x2000.

Dimmer Installation

The dimmer pack is designed to be located upon a solid surface inside a domestic or commercial building as defined by local or national electrical-installation regulations. See Figure 1.1, which details additional guidelines and overall dimensions.

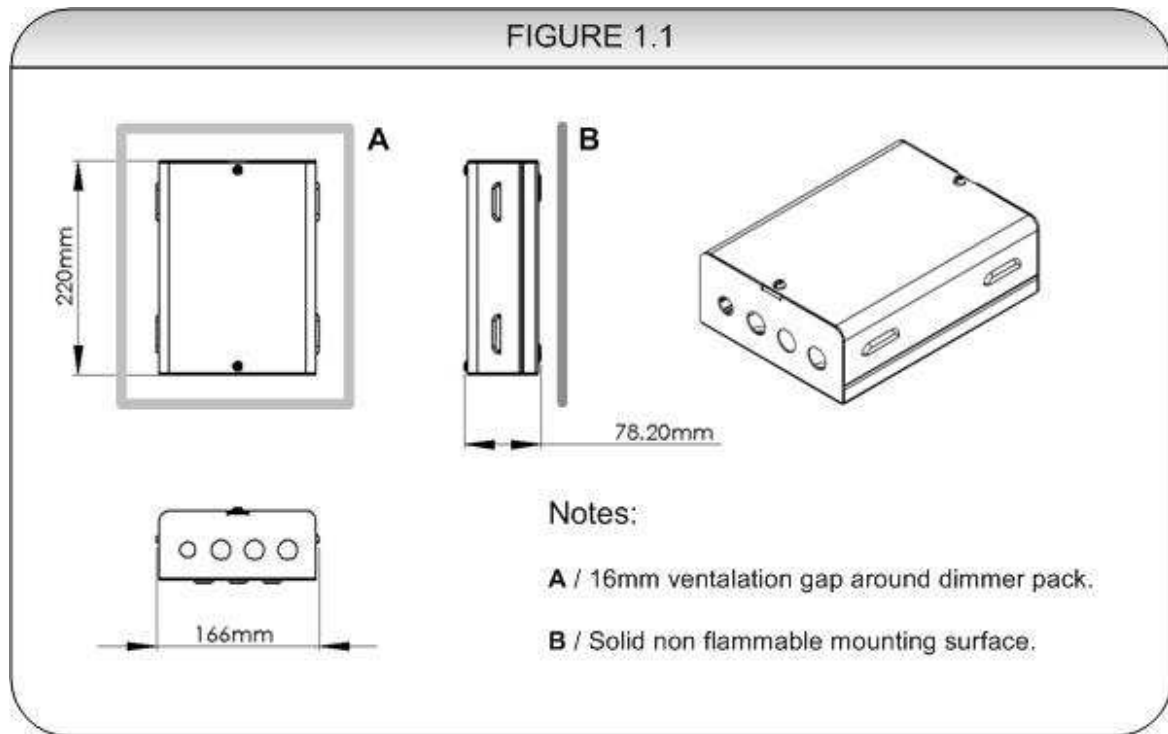

Wiring Diagram

Figure 1.2 details the terminals found on a 2 Channel x 2000-Watt Leading Edge Dimmer (DS2x2000).

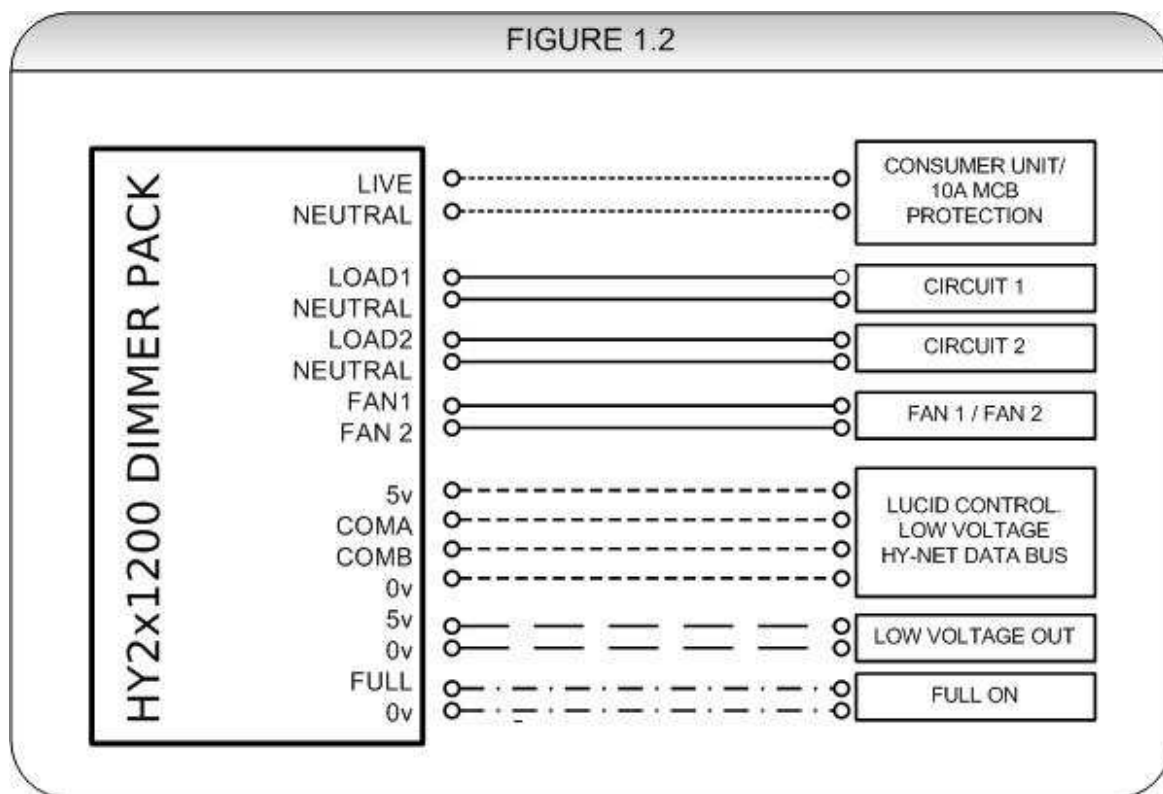

Networking Dimmer Packs

LUCID lighting has provided the ability to network individual dimmer packs together. Dipswitch settings provide zone selection and channel addressing to create a larger scene based lighting system when used alongside LUCID control plates. Figure 1.3 illustrates one method of configuring a network system.

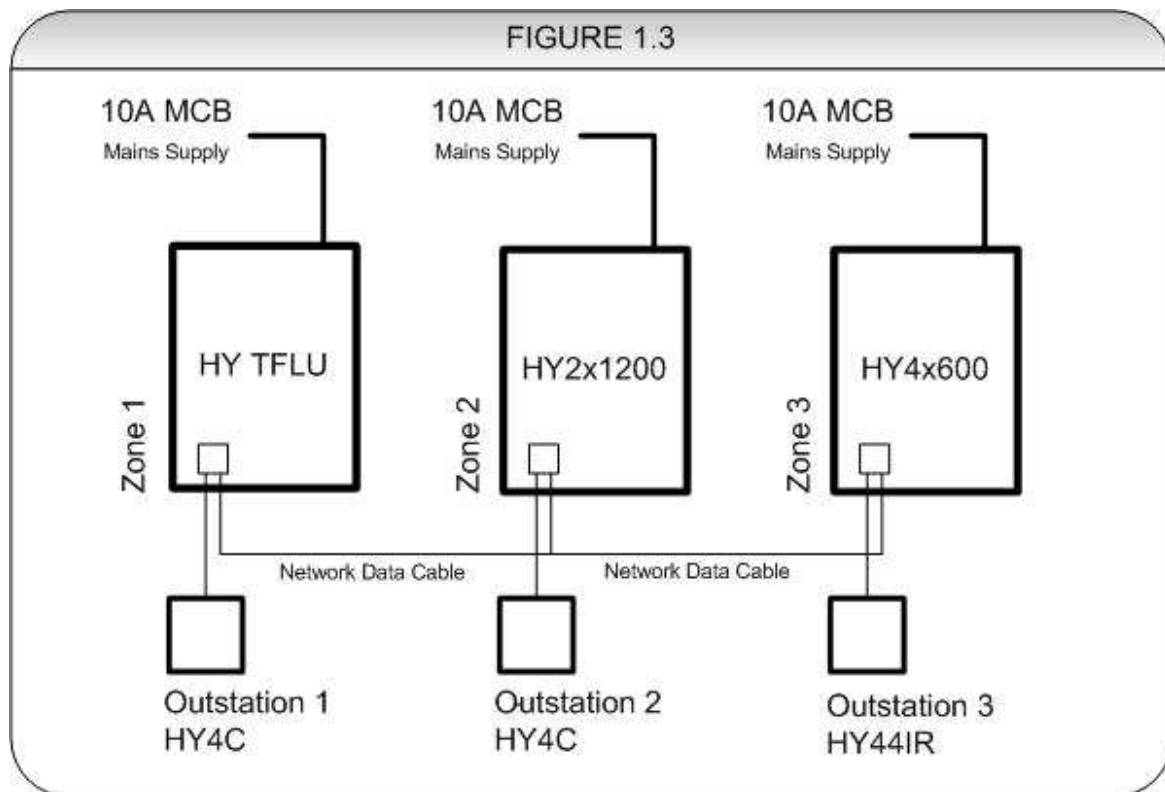

www.lucid-lighting.com

LS Design (UK) Limited, 12 Ty Coch Way, Cwmbran, Gwent, NP44 7HB
T. 01633 877 997 E. lucid@ls-design.co.uk
E&OE